

www.epiroc.homes

Pit Viper 351

Single-pass blasthole drill rigs



Built for performance

The Pit Viper name has become synonymous with productivity in the mining industry, and the Pit Viper 351 is the Pit Viper that started it all.

When it comes to drilling large holes in hard rock, you can't compromise anywhere. The Pit Viper 351's powerful rotary head, high bit load, large compressor and robust structure bring balanced power for the hardest rock. With a 125,000 lb (56.7 tonnes) bit load capacity, the Pit Viper 351 can add unsurpassed productivity to your mining operations.

If technology, productivity and long asset life with the lowest total cost of ownership are on your list of priorities, look no further than the Pit Viper series. Equipped with a standard Rig Control System (RCS) operating platform, today's Pit Viper 351 sets the bar for productivity and reliability when large blastholes are part of the production plan.

+ Key benefits

Highly efficient drilling

The Pit Viper 351 is one of the most efficient rotary tricone drills available for drilling 10 5/8 in to 16 in (270 mm to 406 mm) diameter holes. The Pit Viper 351 can drill an angled or vertical clean hole down to a depth of 65 ft (19.8 m) in a single pass, or a depth of 135 ft (41.1 m) in multi-pass applications. Single-pass drilling can improve drilling efficiency by up to 25% when drilling in soft material by eliminating rod change time and allowing more time for drilling. Eliminating rod changes also reduces the risk for operational errors.

Smooth operation with long life

The Pit Viper 351's patented automatic cable tensioning system ensures an accurate head alignment, improves cable life and eliminates drill downtime for cable tensioning. This design allows smoother drilling, which helps increase the life of the bit and feed system.

Ample power for hard rock

A rotary head with a powerful torque of up to 19,000 ft-lb (25,760 Nm), compressor capacity of up to 3,800 cfm of air, and 125,000 lb (56,700 kg) of weight on bit create a balanced and powerful system to quickly drill through hard rock.

For details on how the Pit Viper series can enhance your profitability contact your Epiroc representative or visit epiroc.com.



Proven systems and technologies designed for today's mining market demands



+ Operator comfort

The Pit Viper 351 features an insulated, pressurized cab with an air-ride operator seat — providing high suspension comfort with excellent visibility. The large cab is equipped with Rig Control System (RCS) controls, providing on-board automation capabilities as part of the standard drill package for added safety and productivity.

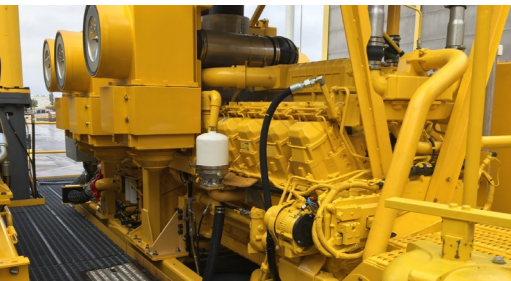

+ Ease of maintenance

The deck layout on the Pit Viper series offers easy access to all major service components. Ground-level, fast fuel fill connections are standard, and optional ground-level live sampling is available.

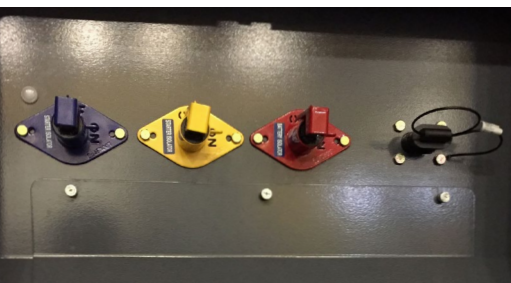

+ Enhanced safety

The Pit Viper 351 is equipped with a number of features to help keep operators safe on the job. Features include a FOPS cab with double safety glass, as well as ground-level battery/tram/starter isolation. The unit also has safety interlocks through the RCS system and safety shutdowns for temperature, low level and pressure. Other features include spring-applied, hydraulic-released brakes on the tramming system, and automation options to further increase safety.



Service and support

Epiroc offers several types of service agreements to meet your operational requirements and maximize your productivity:

Variable-price repairs

Service when you need it.

Fixed-price repairs

Service with controlled costs.

Equipment audit

Scheduled equipment quality control.

Preventive maintenance programs

Peace of mind so you can focus on your core business.

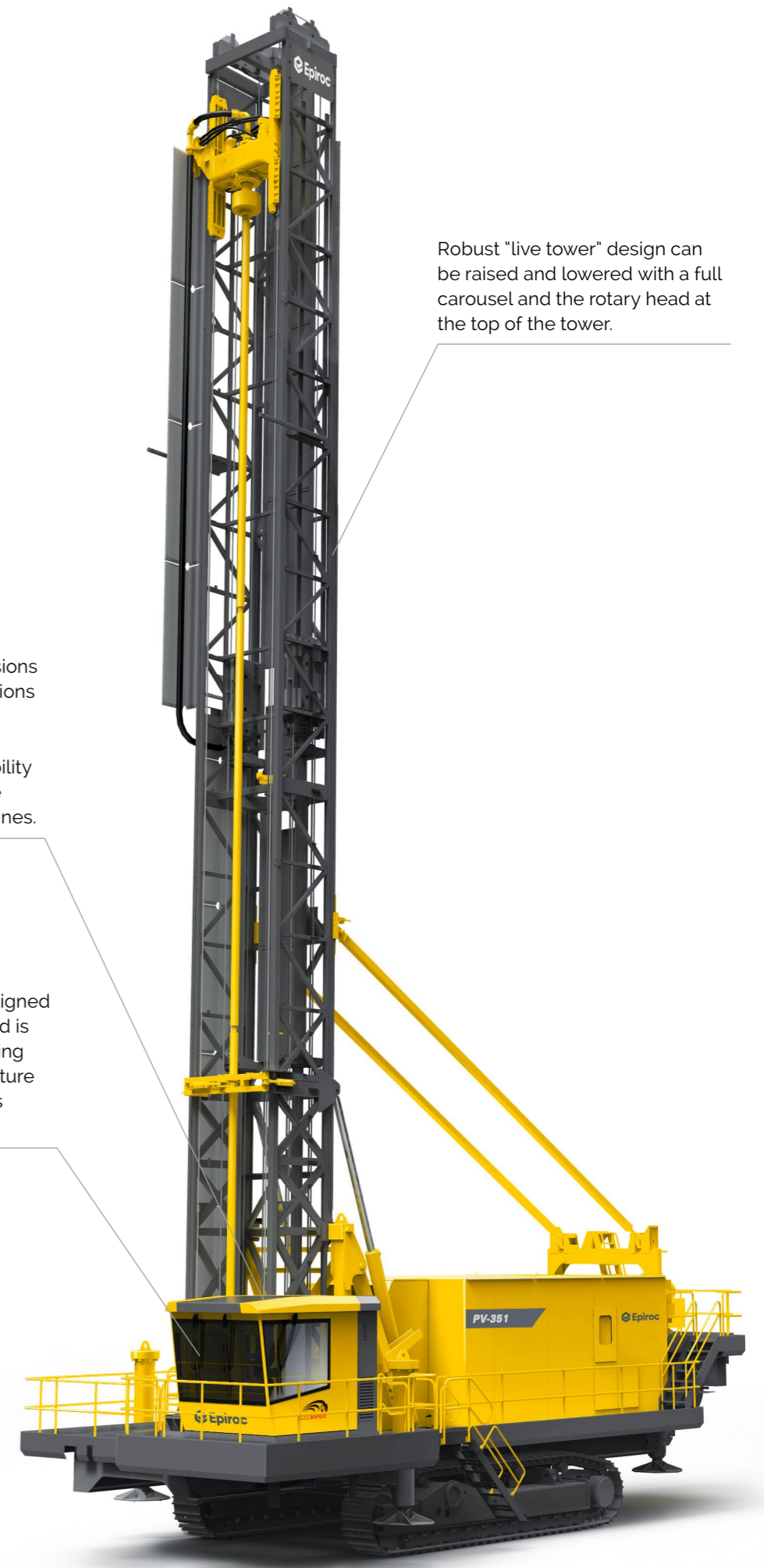

Robust "live tower" design can be raised and lowered with a full carousel and the rotary head at the top of the tower.

Diesel and electric versions are available. Both versions operate on a common drill platform, allowing best-in-class serviceability for mines that need the flexibility of both machines.

Ergonomic cabin is designed for maximum safety and is tested to the same Falling Object Protective Structure (FOPS) requirements as dozers.

Flexibility for the future



Epiroc's Rig Control System (RCS) is based on proven CAN-bus technology and comes standard on the Pit Viper 351. RCS provides a number of safety and interlock features, as well as a foundation to add new functionality/options later without a major rebuild of the machine.

With RCS, you can run your Pit Viper 351 with an operator on board using options such as Autodrill and Autolevel — or you can run with the operator off the drill with the optional BenchREMOTE package, allowing one operator to run one or multiple units. You can even implement autonomous drilling with almost no human interaction with the drill.

Add-on features:

Autodrill

Executes fast, safe and efficient drilling processes in a consistent way.

Autolevel

Closes the gap between less experienced and expert operators.

Wireless remote tramming

Allows the operator to tram a Pit Viper from the bench within a 32.8 – 65.6 ft (10 – 20 m) distance.

Teleremote

Allows safe, productive and effective single- or multi-drill remote operations (control room and drill solutions sold separately).

Automatic Bit Changer

Enables hands-free bit changes so operators can effortlessly switch rotary tricone bits with a simple touch of a button, reducing downtime and boosting efficiency.

High-precision GPS hole navigation system

Imports drill plans to RCS and ensures that each blasthole is precisely positioned with accuracies of up to ±3.9 in (±10 cm), depending on installation and the number of satellites.

Office pack

Includes:

- **Common Communications Interface (CCI)**
Allows data transfer to and from the RCS system.
- **Surface Manager**
Provides production reporting
- **Rig Remote Access (RRA)**
Wirelessly sends files to and from the drill rigs.
- **Desktop Viewer**
Allows remote access to the drill's operational screens.



Technical specifications

Sub structure

Mainframe

- Weld fabricated I-beam type
- Designed by Epiroc and weld fabricated by certified welders
- Designed with the latest FEA technology and verified by dynamic strain gauging 326 lb/ft (485 kg/m)

Leveling Jack

Type	Hydraulic cylinder
Quantity	Four jacks
Calculated jack pad bearing pressure	88 psi (607 kPa)
Position indication	"Jack up" indicator lights on console or RCS screen with proximity switches

Capacities

Fuel tank	1,200 gal (4,542 L)
Water tank (diesel)	900 gal (3,407 L) or 1,000 gal (3,785 L)
Water tank (electric)	900 gal (3,407 L), 1,500 gal (5,678 L) or 2,100 gal (7,949 L)
Hydraulic tank	360 gal (1,363 L)

Undercarriage and propel system

Make	Epiroc custom or Caterpillar custom
Mounting	Oscillating walking beam: 5' each side, total 10'
Total length	Epiroc: 27 ft (8.23 m), Caterpillar: 26 ft 10 in (8.18 m)
Ground contact	Epiroc: 23 ft (7.01 m), Caterpillar: 22 ft 10 in (6.96 m)
Take-up adjustment	Hydraulic slack adjustment; spring recoil
Rollers	Epiroc: 13 lower / 4 upper, Caterpillar: 13 lower / 5 upper
Location	Equally spaced between idler and sprocket
Roller bearings	Sealed for life
Track pads	Type: Double bar grouser Width: Epiroc – 29.5 in (749 mm), Caterpillar – 26.5 in (650 mm) Ground pressure: Epiroc – 25.5 psi (175.8 kPa), Caterpillar – 29.6 psi (204.1 kPa)
Drive	Hydrostatic closed loop through speed reducer to drive sprockets
Propel motors	Two - Hydraulic, axial piston, fixed displacement Rating (each): Epiroc – 358 HP (267 kW), Caterpillar – 346 HP (258 kW)
Propel speed range	Epiroc: 0 – 1 mph (0 – 1.6 km/h), Caterpillar: 0 – 1.1 mph (0 – 1.8 km/h)

Technical specifications

Tower, carousel and drill rod handling

Tower	
Tower construction	Four member with open front ASTM A500 Grade B rectangular tubing
Tower raising	Two hydraulic cylinders; live tower (raise and lower with full carousel and rotary head at top of tower)
Rod support	Hydraulic cylinder clamping and actuation to center drill rod
Rated Capacity	
Single pass depth	65 ft (19.8 m)
Maximum hole depth	135 ft (41.1 m)*
Carousel (carousel internal to the tower with key-lock retention)	
Rod length	35 ft (10.7 m)
Capacity	Two pieces
Acuation	Two hydraulic cylinders
Safety	<ul style="list-style-type: none"> • Drill pipe is held securely in carousel by "key lock design" mechanism • No bump system to prevent damage if carousel not stowed

Drill rods		
Drill pipe diameter x 35 ft (10.7 m)	Thread	Suggested bit diameter
8-5/8 in (219 mm)	6 in BECO	10-5/8in – 11 in (270 mm – 279 mm)
9-1/4 in (235 mm)	6 in BECO	11 in – 12-1/4 in (279 mm – 311 mm)
9-3/4 in (248 mm)	7 in BECO	12-1/4 in (311 mm)
10-3/4 in (273 mm)	8 in BECO	12-1/4in – 13-3/4 in (311 mm – 349 mm)
12-3/4 in (324 mm)	8 in BECO	15 in – 16 in (381 mm – 406 mm)
13-3/8 in (340 mm)	10 in BECO	16 in (406 mm)

Rotary head	
Speed range	Variable 0 – 170 RPM
Torque	Variable 0 – 19,000 lbf-ft (0 – 25,760 Nm)
Number of motors	Two
Type of motor	Variable displacement axial piston
Reduction	Two-stage spur gear (14.8:1)
Horsepower	358 HP (267 kW)
Travel length	77 ft 6 in (23.62 m)

Feed system	
Pulldown capacity	Up to 125,000 lbf (up to 556 kN)
Pullback capacity	Up to 75,000 lbf (up to 334 kN)
Weight on bit	Variable, 0 – 125,000 lb (0 – 56,700 kg)
Mechanism type	Two dual rod, dual piston hydraulic cylinders (patented design)
Number of cables – diameter	Two pulldown – 1 1/4 in (31.7 mm) Two pullback – 1 1/8 in (28.6 mm)
Number of sheaves – outside diameter	Four pulldown – 26 in (660.4 mm) Six pullback – 24 in (609.6 mm)
Automatic Tensioning	Static tensioning on pulldowncable (hydraulic motor actuated); dynamic tensioning on pullback cables
Feed speed	126.7 ft/min (38.6 m/min)
Retract speed	158.1 ft/min (48.2 m/min)

* Maximum hole depth only achieved with certain pipe sizes and wall thickness.

Technical specifications

Cab and controls

Cab	
<ul style="list-style-type: none"> • Quiet, single piece design with no seams or leaks (tested @ less than 80 dBA) • Insulated, pressurized with heater and under cab mounted air conditioning • Falling object protective structure (FOPS) certified • Ergonomically designed control system and excellent visibility (with unobstructed view to drill table) 	

Controls (Rig Control System – RCS)	
RCS Control	<p>Integrated control touchscreen (penetration rate, rotation torque, rotation pressure, pulldown force, pulldown pressure, hole depth indicator, etc.)</p> <p>Two joy sticks (attached to the operator's seat) and push buttons on the operator panel controls (propel and leveling jack, pulldown feed control, holdback feed control)</p> <p>Standard interlocks/features</p>

Hydraulic system	
<ul style="list-style-type: none"> • Five hydraulic pumps mounted on a five-hole gearbox driven directly by the engine • Two main piston pumps – drilling functions (drill feed and rotation) or tram functions (propel) • Two auxiliary piston pump – auxiliary functions • One piston pump – cooler package fan 	

Power package

Airend	
Diesel Rig	3,000 cfm / 110 psi (84.9 m ³ /min / 7.6 bar)
Electric Rig	3,800 cfm / 110 psi (107.6 m ³ /min / 7.6 bar)
	3,000 cfm / 110 psi (84.9 m ³ /min / 7.6 bar)
	3,200 cfm / 110 psi (90.6 m ³ /min / 7.6 bar)
	3,800 cfm / 110 psi (107.6 m ³ /min / 7.6 bar)

Electronic Air Regulation System (EARS)	
<ul style="list-style-type: none"> • Electronic Air Regulation System (EARS) comes standard on the PV-351 • Compressor regulation • Two butterfly valves varying the inlet of the airflow (decreased airflow while maintaining constant restriction) • Optimal fuel efficiency while hole collaring • Reduced wear on drill string components 	

Diesel engine	
Diesel engine – non Tier 4	CAT C3512 T1 – 1,650 HP (1,230 kW) Cummins QSK45 T1 – 1,500 HP (1,118 kW)
Diesel engine – Tier 4	QSK50 T4F – 1,500 HP (1,118 kW)
Electric motor*	WEG 6811 – 1,400 HP @ 50Hz or 60 Hz (1,044 kW)

* Airend output differs between 50Hz and 60 Hz operations.

Technical specifications

Shipping dimensions and weight (standard machine)

Tower	
Length	97 ft 8 in (29.77 m)
Width	12 ft 7 in (3.84 m)
Height	10 ft (3.05 m)
Gross weight	99,600 lb (45 tonnes)
Track (each)	
Length	37 ft 3 in (8.31 m)
Width	3 ft 10 in (1.17 m)
Height	6 ft 1 in (1.85 m)
Gross weight	38,500 lb (17.5 tonnes)
Main frame – diesel (stripped)**	
Length	49 ft 6 in (15.09 m)
Width	15 ft 7 in (4.75 m)
Height	13 ft 4 in (4.06 m)
Gross weight	142,700 lb (64.7 tonnes)
Main frame – electric (stripped)**	
Length	50 ft 6 in (15.39 m)
Width	16 ft 8 in (5.08 m)
Height	14 ft 4 in (4.37 m)
Gross weight	145,400 lb (65.9 tonnes)
Operating weight	
Estimated weight	375,000 – 415,000 lb (170 – 188 tonnes)

Operating dimensions***

	Description	Dimensions ft (m)
A	Height – tower up	103' 2" (31.45)
B	Length – tower up	58' 11" (18)
C	Length – tower down	100' (30.48)
D	Length – undercarriage	26' 10" (8.19)
E	Length – jack center to jack center	36' 6" (11.12)
F	Height – ground to jack drill end	2' 2" (0.67)
H	Height – tower down	26' 11" (8.20)
I	Width – track inside to track inside	15' 1" (4.59)
J	Width – jack center to jack center	22' 11" (6.98)
K	Width – overall	28' 8" (8.74)
L	Width – decking	5' 3" (1.60)
M	Width – track	2' 6" (0.75)
N	Height – tower off	20' 8" (6.30)
P	Height – to lowest point	1' 4" (0.39)
V	Height – top of cab to ground	15' 4" (4.68)
AA	Height – jack to ground non drill end	2' 5" (0.74)

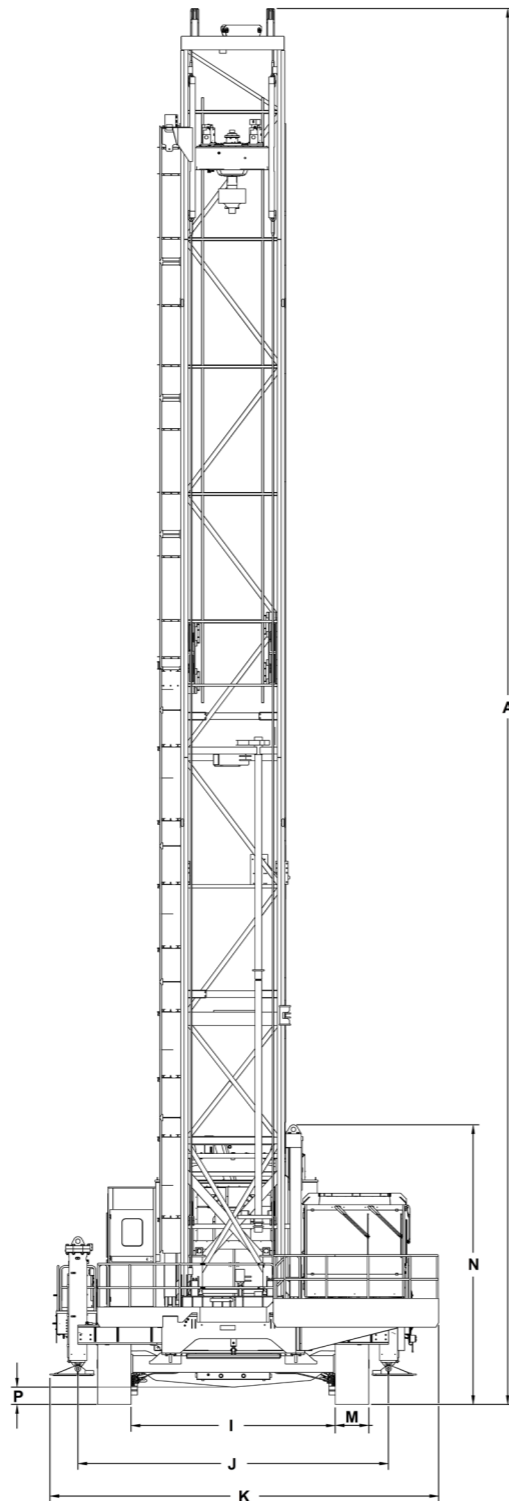

Technical specifications

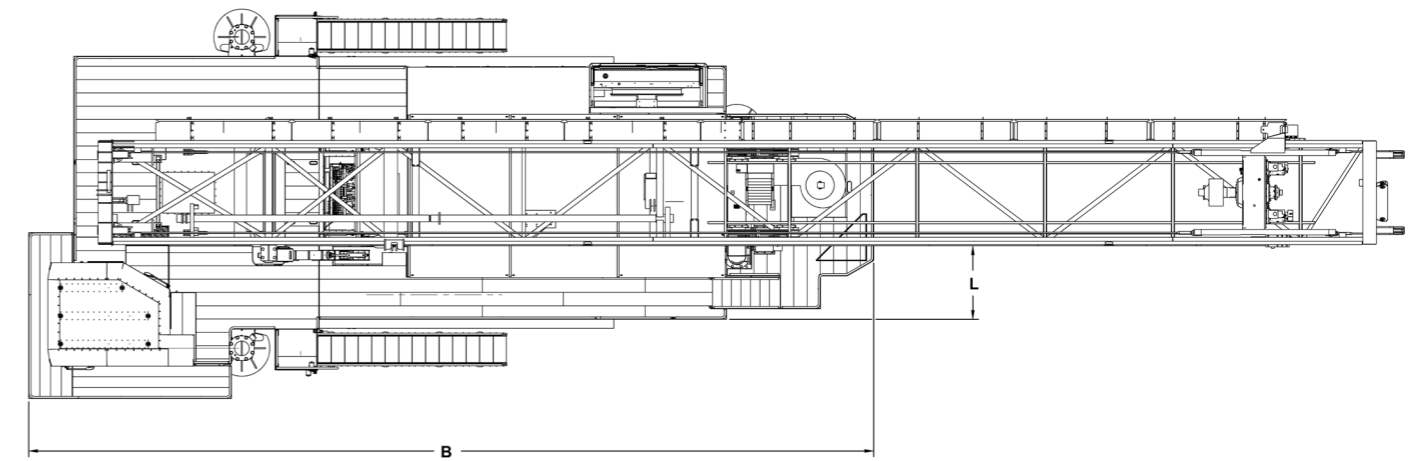
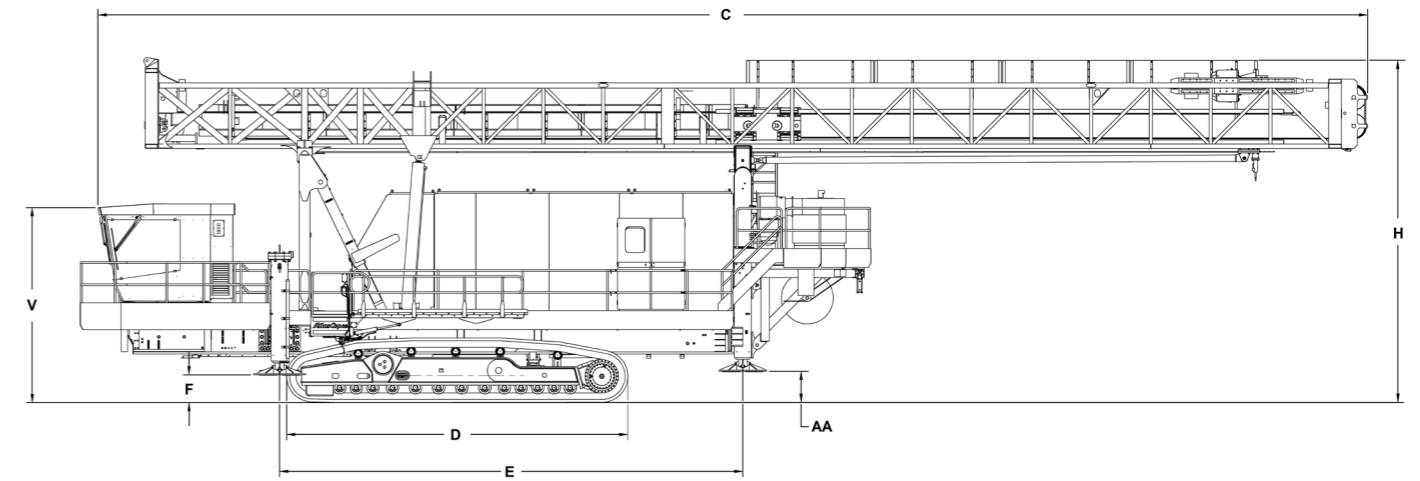

*Approximate shipping dimensions for crated PV-351 (actual dimensions will vary based on rig configuration).

**Fall off will vary greatly by machine and options.

***Dimensions for PV-351 electric with Caterpillar tracks (actual dimensions may vary by machine and options).

Optional equipment

Following are some examples of available options. For a comprehensive list, please contact your local Epiroc Customer Center.

- Wrap-around decking for 360° access around cab
- Ground-level fast service panel
- Angle drilling package
- Hydraulic retractable stair
- Automatic thread lubrication
- Bit viewing hatch
- Water injection system
- Dust collector system
- Auxiliary crane
- Video camera system
- Cold weather equipment

**United in performance.
Inspired by innovation.**

Performance unites us, innovation inspires us, and commitment drives us to keep moving forward. Count on Epiroc to deliver the solutions you need to succeed today and the technology to lead tomorrow.

[epiroc.com](https://www.epiroc.com)

